

MODEL BAC2

Parts Book & Manual



NC Carpet Binding
858 Summer Ave
Newark, NJ 07104

P 973-481-3500 www.NCCarpet.com

DESCRIPTION

Machines of Class 300U are high speed, compound feed, two thread chainstitch machines designed for general stitching operations on materials of medium and heavy weight.

These machines are available for single and multiple stitching operations such as seaming, binding, welting, lap seam felling, etc. They perform outstanding work on trousers, work clothing, automotive upholstery, tents, tarpaulins, seat covers and a variety of other products.

General Characteristics

Belt driven arm shaft mounted in front and rear ball bearings.

Belt driven bed shaft.

Semi-automatic lubricating system with large capacity oil reservoir in upper and lower shafts lubricates all principal bearings.

Presser foot is raised by a treadle operated foot lifter which also release the needle thread tension.

Space at right of needle, 10 inches.

Special Features

Machine 300U 101

One needle and one looper.
Stitch length, 4 to 12 per inch.
Needle bar stroke, 1-1/4 inches
Clearance under presser foot, 5/16 inch.

Machine 300U 103

One needle and one looper.
Alternating pressers.
Stitch length, 4 to 12 per inch.
Needle bar stroke, 1-1/4 inches.
Clearance under presser foot, 1/4 inch.

Machine 300U 105

One needle and one looper.
Gear driven Puller Feed.
Stitch length, 4 to 12 per inch.
Needle bar stroke, 1-1/4 inches.
Clearance under presser foot, 5/16 inch.

Machine 300U 201

Two needles and two loopers.
Stitch length, 4 to 12 per inch.
Needle bar stroke, 1-1/4 inches.
Clearance under presser foot 5/16 inch.
Gauges (Needle Spacing): 3/16 inch to 2 inches in steps of 1/32 inch.
Standard gauges, 3/16 inch, 1/4 inch.

Machine 300U 203

Two needles and two loopers.
Alternating pressers.
Needle bar stroke, 1-1/4 inches.
Stitch length, 4 to 12 per inch.
Clearance under presser foot, 1/4 inch.
Gauges (Needle Spacing): 3/16 inch to 1 inches in steps of 1/32 inch.
Standard gauges, 1/4 inch.

Machine 300U 205

Two needles and two loopers.
Gear driven Puller Feed.
Stitch length, 4 to 12 per inch.
Needle bar stroke, 1-1/4 inches.
Clearance under presser foot, 5/16 inch.
Gauges (Needle Spacing): 3/16 inch to 2 inches in steps of 1/32.
Standard gauges, 3/16 inch, 1/4 inch.

Machine 300U 401

Four needles and four loopers.
Stitch length, 4 to 12 per inch.
Needle bar stroke, 1-1/4 inches.
Clearance under presser foot, 5/16 inch.
Gauges (Needle Spacing): 3/4 inch to 2 inches between outside needles.
Standard gauges, 1/4 inch - 1 inch - 1/4 inch.

Machine 300U 405

Four needles and four loopers.
Gear driven Puller Feed.
Stitch length, 4 to 12 per inch.
Needle bar stroke, 1-1/4 inches
Clearance under presser foot, 5/16 inch.
Gauges (Needle Spacing): 3/4 inch to 2 inches between outside needles.
Standard gauges, 1/4 inch - 1 inch - 1/4 inch.

Machine 300U 194

One needle and one looper.
Alternating pressers with pneumatic pressure control.
Stitch length 3-1/3 to 12.
Needle bar stroke 1-7/16 inches.
Clearance under presser foot, 7/16 inch.

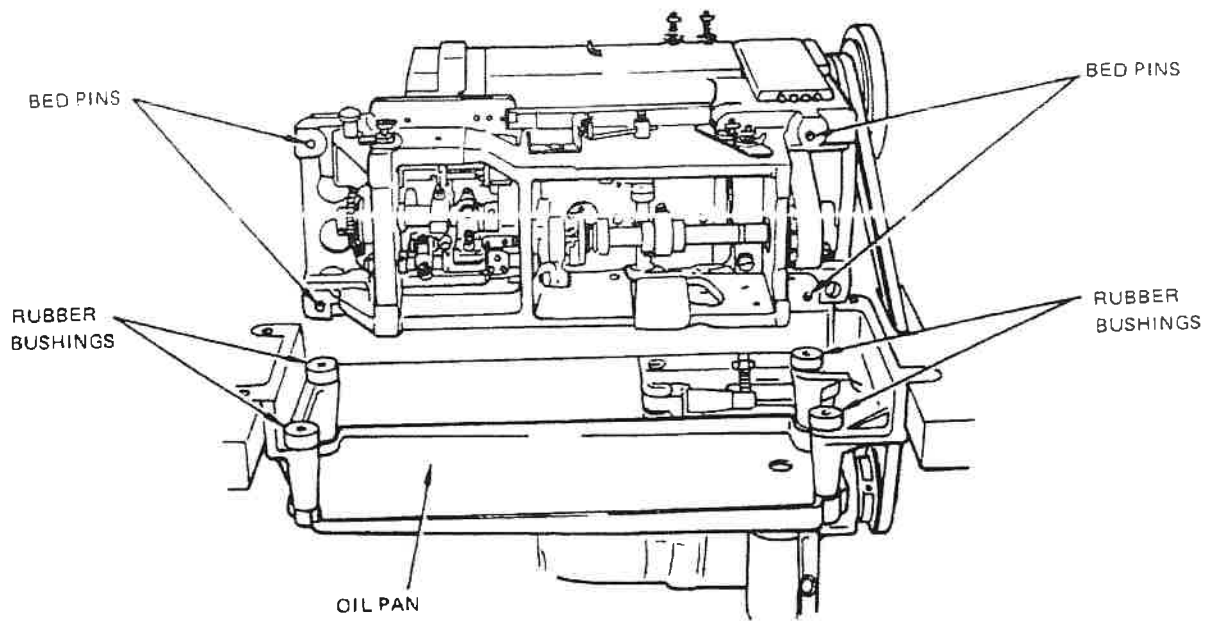

Fig. 2

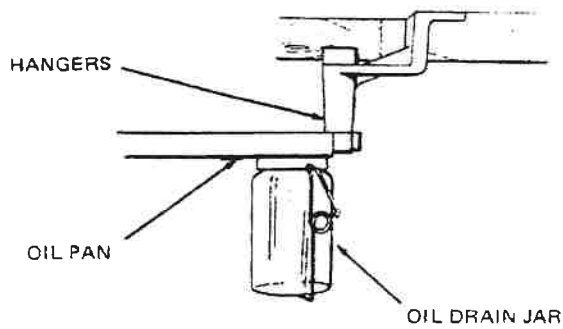

Fig. 3

INSTALLATION

Assemble oil pan to hangers. Insert assembled oil pan into machine cut-out of table placing four rubber bushings in hanger holes as shown in Fig. 2. Attach oil drain jar to oil pan as shown in Fig. 3.

Place machine on oil pan assembly with the four bed pins passing through the four rubber bushings shown in Fig. 2.

connect foot lifter treadle to foot lifter lever, Fig. 4, at back of machine by chain furnished for this purpose.

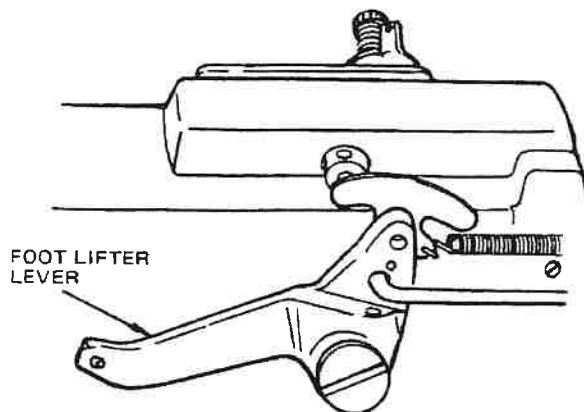

Fig. 4

LUBRICATION

Machines of Class 300U have a semi-automatic lubricating system comprising a hollow arm shaft and a hollow bed shaft which act as oil reservoirs. The oil is distributed to all of the principal bearings by centrifugal force through small jets in the shafts when the machine is in operation. Provision is also made for hand lubricating other movable parts which are not lubricated from the reservoirs.

CAUTION: Use SINGER* OIL, "TYPE B" or "TYPE D". Use "TYPE D" OIL when an oil is desired which will produce minimum stain on fabrics even after long period of storage.

Do not use additives in sewing machine oil as they may cause a reduction in the normal flow of oil that can result in damage to the machine.

BEFORE STARTING machine, the machine must be oiled as instructed. Failure to do this will result in damage to the machine.

Pressure Oil Can, furnished with the machine, is to be used to oil all points requiring lubrication.

TO OIL ARM SHAFT

To fill arm shaft reservoir, insert spout of pressure oil can in hole, Fig. 5, and inject 1 shot of oil into shaft twice daily.

TO OIL BED SHAFT

To fill bed shaft reservoir, push spring cover, Fig. 6, to the left, insert spout of pressure oil can into hole and inject 1 shot of oil into shaft twice daily. Close oil hole spring cover.

NOTE: Bed shaft may also be oiled from right hand end of machine.

OTHER OILING POINTS

Apply oil to all work plate and arm oil holes, needle bar bearings and connections, needle bar rock frame bearings, looper rocker sleeve and presser lifting mechanism.

CAUTION: For machines in continuous use, all oiling points must be oiled daily. Occasionally oil tension release mechanism and looper pull-out rack.

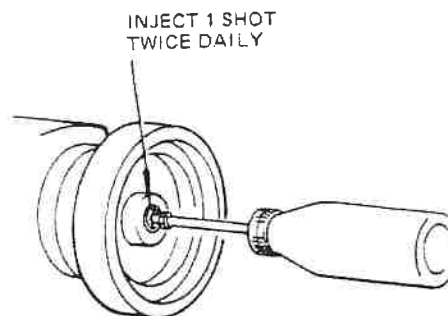

Fig. 5

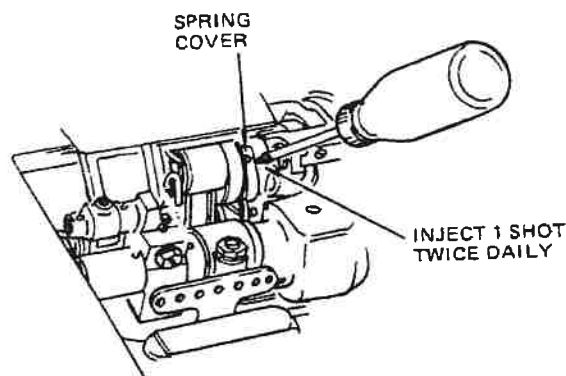

Fig. 6

SPEED

Maximum speed for machines 300U103, 300U194 and 300U203 is 4000 stitches per minute.

It is advisable to operate new machines at a speed of 500 stitches less than maximum for the first 100 hours of operation.

Maximum efficient speed is determined upon the nature of the operation, the ability of the operator and the type of material being sewn.

Maximum speed for Machines 300U101, 300U105, 300U201, 300U205, 300U401 and 300U405 is 4500 stitches per minute.

NEEDLES

Machines 300U101, 300U105, 300U201, 300U205, 300U401 and 300U405:

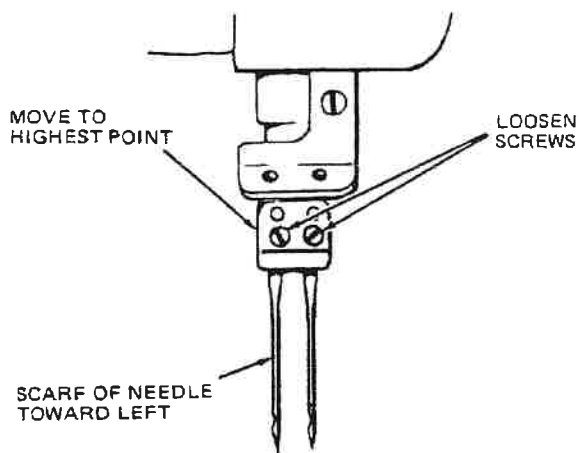
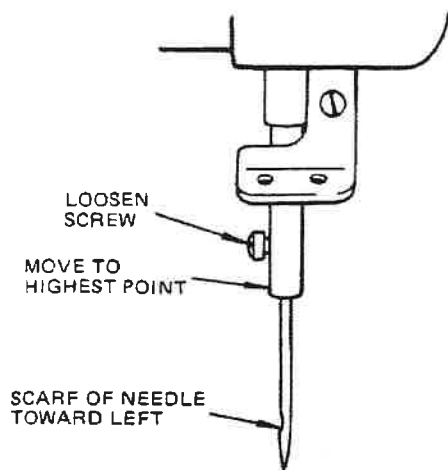

Fig. 7

Use SINGER* Needles, Catalog 3260 (62x57)

For heavier weight material, needle Catalog 4112 (62x59) may also be used. In this case, the needle bar must be adjust as instructed on page 13.

Machines 300U103, 300U203 and 300U194:

Use SINGER* Needles, Catalog 4112 (62x59) for medium heavy work or Catalog 3260 (62x57) for medium light work.

The size of the needle to be used is determined by the size of the thread which must pass freely through the eye of the needle.

Orders for needles should specify quantity required, size number and catalog number.

To Set The Needle

Turn machine pulley over toward the operator until the needle bar is at its highest point, as shown in Fig. 7.

Loosen needle set screw on single needle machines or needle clamping screws on multiple needle machines, as shown in Fig. 7.

Insert needle into needle bar or clamp as far as it will go making certain that the scarf of each needle faces toward the left, as shown in Fig. 7.

THREAD

Either left twist or right twist thread may be used in the needles and loopers.

Rough or uneven thread, or thread which passes through the needle eye with difficulty will interfere with successful operation of the machine.

THREADING THE MACHINE

Upper Threading

Turn machine pulley over toward operator until needle bar is at its highest point.

Pass thread from unwinder through threading points indicated in Fig. 8. See insert, Fig. 8, for correct threading of needle.

Draw approximately two inches of thread through needle eye with which to start sewing.

Single and multiple needle machines are all threaded as shown in Fig. 8. Make certain that each thread passes through thread tension device.

Machines of Class 300U having Alternating Pressers are equipped with a thread lubricator on front of the arm. The needle thread must pass through the lubricator.

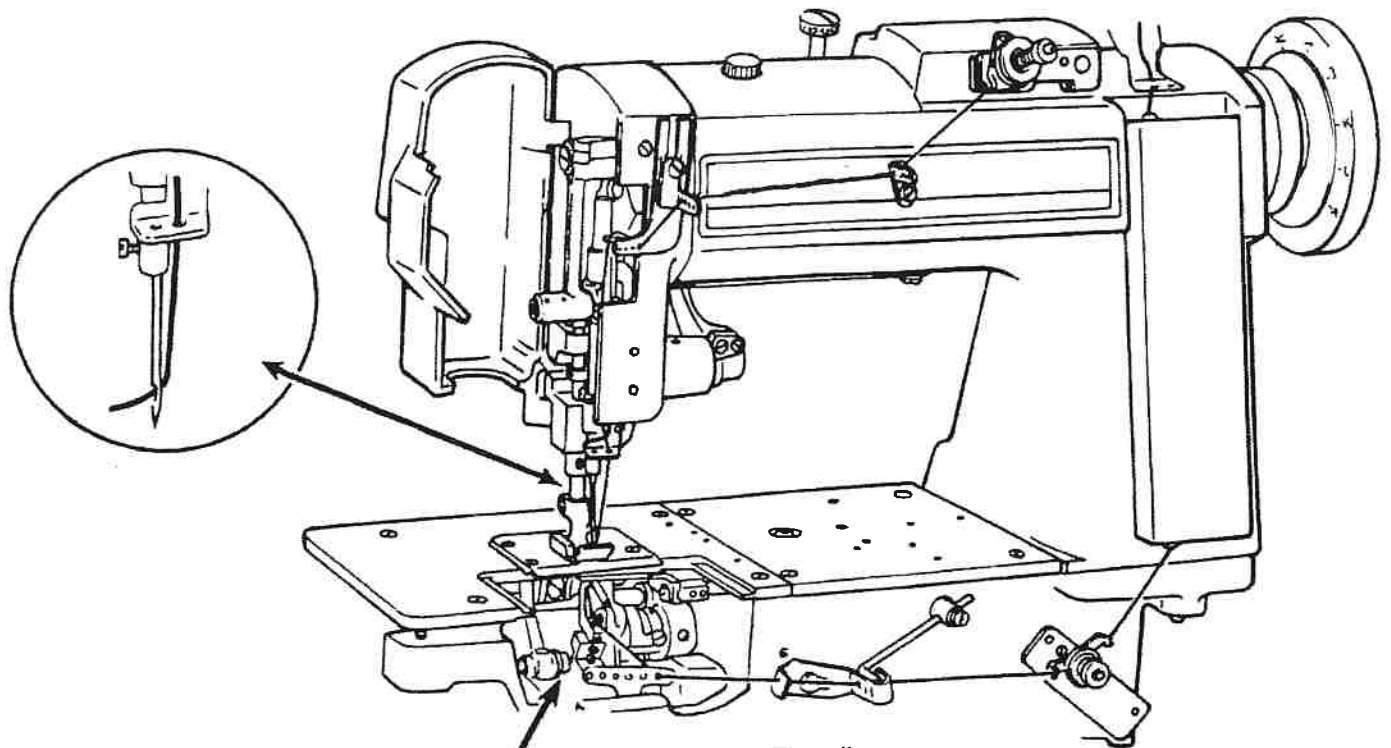

Fig. 8

Lower Threading

Open front table section, remove bed slide and turn machine pulley over toward operator until needle bar is at its highest point.

Move loopers out of sewing position by pulling looper throw-out gear locking plunger rod and looper throw-out rack rod, Fig. 8, out as far as possible. This will place loopers in position for easier threading and prevent accidental operation of machine until loopers are returned to sewing position.

LOOPER THROW-OUT
RACK ROD

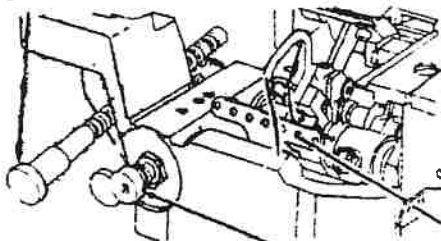

LOOPER THROW-OUT
GEAR LOCKING PLUNGER ROD

Threading The Loopers

Pass thread from unwinder through threading points as indicated. Draw approximately two inches of thread through looper eye with which to start sewing.

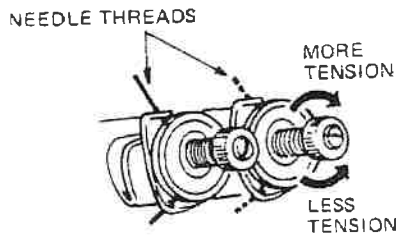

Fig. 9

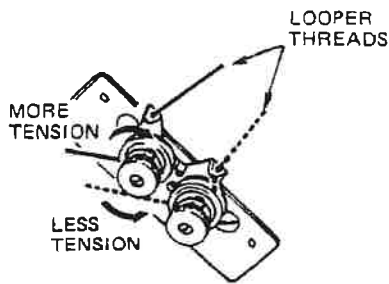

Fig. 10

PRESSURE

Pressure on material should be as light as possible while still sufficient to insure correct feeding.

Presser Foot Pressure

To regulate presser foot pressure, loosen lock screw, Fig. 11, at rear of machine. Tighten thumb screw to increase pressure; loosen to decrease pressure. When correct feeding pressure is attained, tighten lock screw.

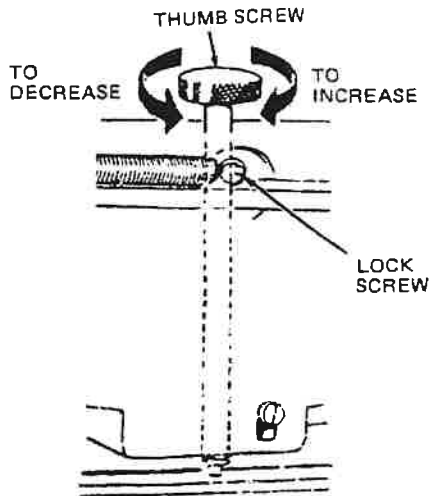

Fig. 11

TENSION

Tension on thread should be light as possible while still sufficient to set the stitch correctly in material.

Needle Thread Tension

To regulate needle thread tension, turn thumb screw, indicated in Fig. 9, as may be required.

IMPORTANT: Regulate needle thread tension only when presser foot is down.

Looper Thread Tension

To regulate looper thread tension, turn thumb screws, as indicated in Fig. 10, as may be required.

Alternating Pressers:

To increase pressure, loosen lower lock nut and loosen lock screw, then tighten upper lock nut, see Fig. 12. When correct pressure is attained, tighten lock screw. Then tighten the lower lock nut. To decrease pressure, loosen upper lock nut and loosen lock screw, then tighten lower lock nut. When correct pressure is attained, tighten lock screw. Then tighten the upper lock nut.

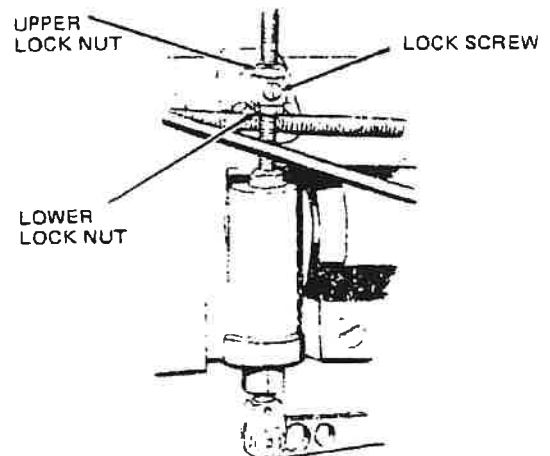

Fig. 12

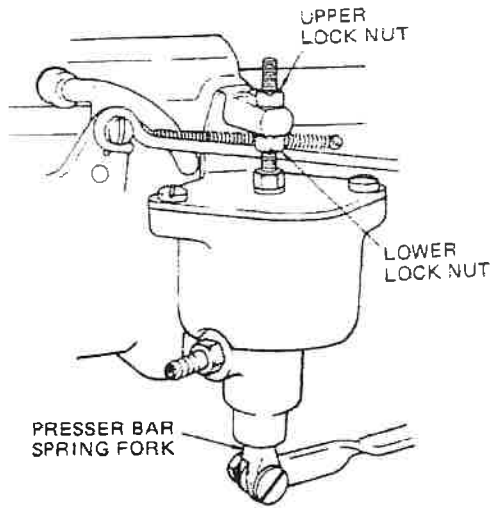

Fig. 13

Alternating Presser with Pneumatic Pressure Control:

Adjust height of Pressure Cylinder with presser feet resting on throat plate. There should be a clearance of 1/4 inch between the Presser Bar Spring Fork and the bottom of the cylinder. To raise cylinder, loosen lower lock nut and tighten upper lock nut, see Fig. 13. To lower cylinder, loosen upper lock nut and tighten lower lock nut. When correct adjustment is attained, tighten both lock nuts.

Regulate air pressure. The correct air pressure is set for average feeding when the Presser Bar Spring Fork rises to approximately 1/16 inch from the bottom of the cylinder.

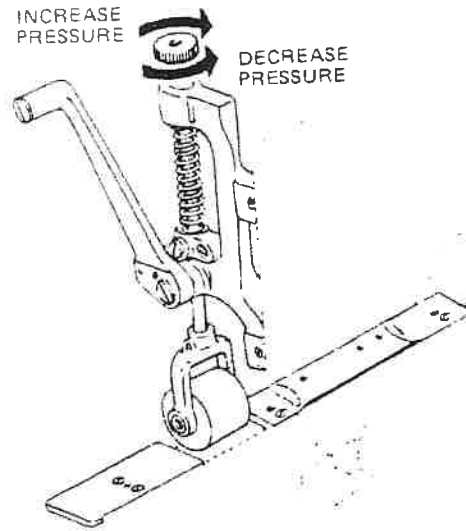

Fig. 15

Upper Feed Roll Pressure

To regulate pressure of the upper feed roll, turn thumb screw as shown in Fig. 15.

STITCH LENGTH

To adjust the stitch length, depress plunger, Fig. 16, located on top of arm. Continue to hold plunger down and turn machine pulley toward operator until plunger enters notch in arm shaft eccentric. Then turn plunger to lock in position. Depress button, Fig. 16, located on machine bed. Hold down, and turn machine pulley toward operator to increase length of stitch, or away from operator to decrease length of stitch. Letter "A" on machine pulley indicates the longest stitch. When desired length, indicated by letter, is opposite arrow on front of machine, release button and turn plunger to right or left until it springs outward.

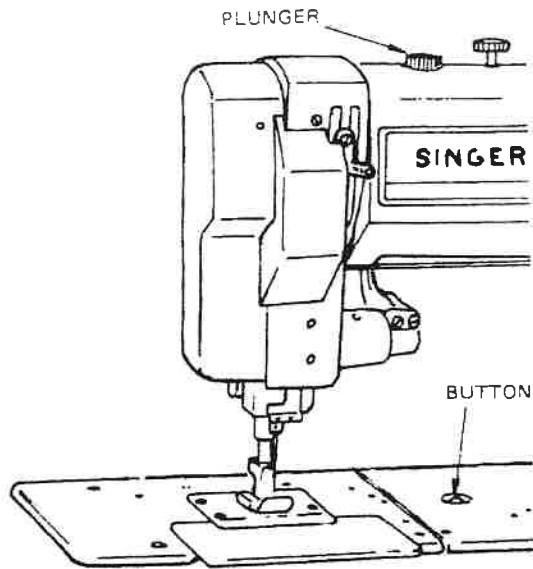

Fig. 16

CAUTION: Never turn machine pulley with plunger in locked position until button on machine bed is depressed.

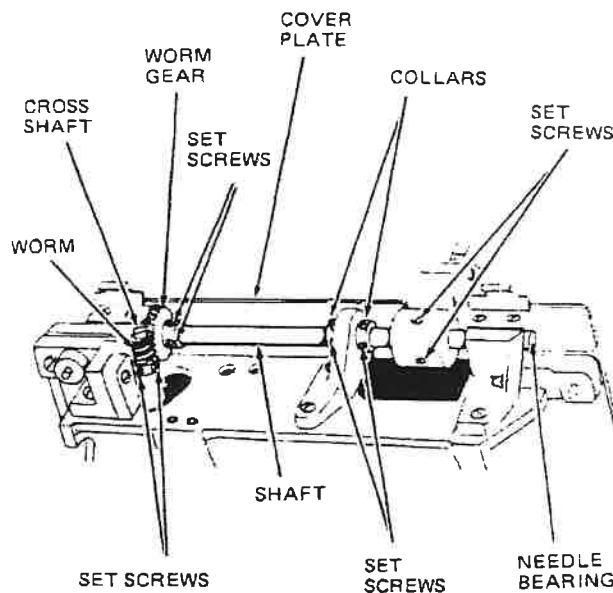

Fig. 17

Machine with Puller Feed

The length of the stitch is determined by the stitch gears in the puller feed mechanism. The compound feed stitch length should be set slightly shorter than the stitch length of the puller feed.

To change Puller Feed gears for adjusting stitch length, remove the two cover plate screws and remove cover plate, Fig. 17. Loosen set screws. Slide puller feed shaft to the right far enough to allow removal of worm and worm gear. Place the new worm on cross shaft. Turn worm in the operating direction and tighten the first set screw into the flat of the shaft. Then securely tighten both set screws, checking for excessive end play. Engage the new worm gear with the worm and slide puller feed shaft through the worm gear until the end of the shaft is flush with the needle bearing. Remove end play in the shaft by setting the two collars against the bracket and tightening the four set screws. Align the lower feed roll with the upper feed roll and tighten the two set screws. Center the worm gear on the center of the worm. Tighten the two set screws with the first screw in the spline of the shaft. Replace cover plate and adjust the compound feed.

PRESSER BAR LIFT

When the presser foot is raised by the presser bar lifter and the needle is at its highest position, the point of the needle should not protrude below the presser foot.

To adjust, turn machine pulley over toward operator until needle is at its highest position. Loosen set screw, Fig. 18. Raise presser foot to the correct height, place stop collar against upper bracket, and tighten the set screw.

Machines with Alternating Pressers

The lift of the vibrating and lifting pressers is controlled by an adjustable eccentric. To adjust, remove arm cover at rear of machine. Turn machine pulley over toward operator until feeding presser is down. Loosen the two lock screws, Fig. 19, and the two clamp screws. Insert screw driver into notch of adjusting disc, and turn machine pulley as indicated in Fig. 19. Then tighten the two clamp screws and the two lock screws.

When it is desirable to have either one of the pressers lift higher than the other, turn machine pulley over toward operator until the lifting presser is at its highest position. Loosen the two clamp screws, Fig. 20, and turn lifting rock shaft crank up or down until desired lift of each presser is attained. Then tighten the two clamp screws.

CAUTION: Limit lift of pressers to minimum required for the work, as this permits higher speeds.

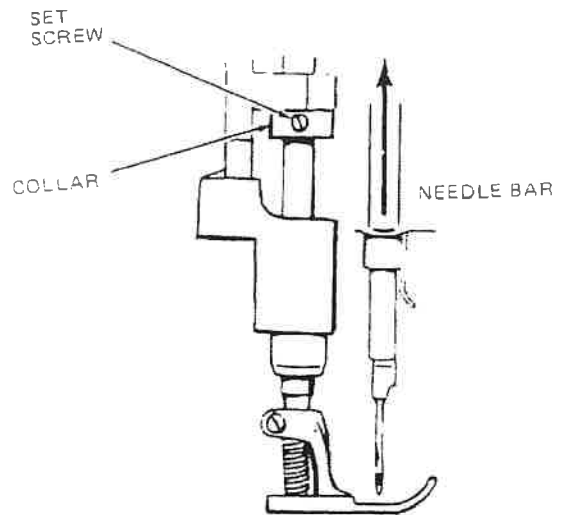

Fig. 18

The vibrating presser should be timed so that under normal sewing conditions, the presser foot will seat on the material at approximately the same time the needle enters material. This timing can be advanced or retarded slightly depending on the type of operation being performed, such as sewing over seams. To adjust, loosen two holding screws, Fig. 20, not more than one half turn. Then turn the adjustable eccentric, Fig. 19, until the vibrating presser seats at the correct time. Securely tighten the two holding screws after adjustment is made.

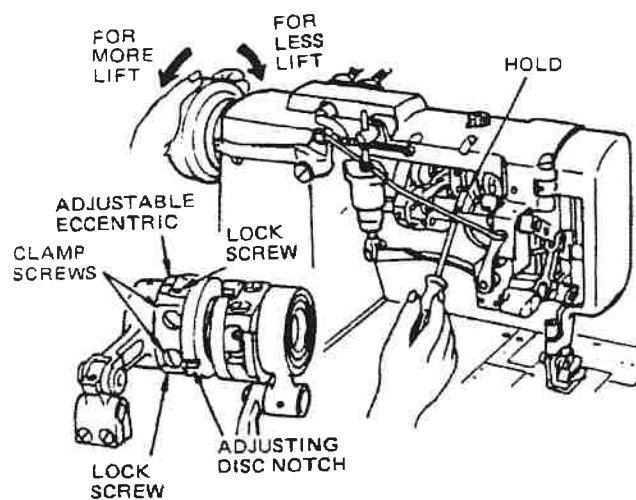

Fig. 19

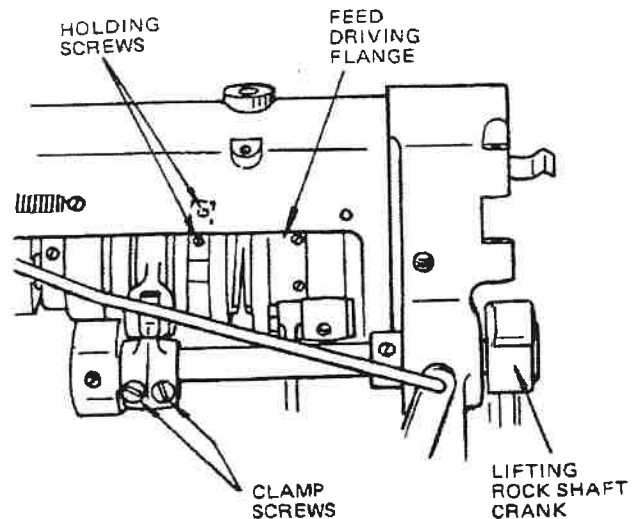

Fig. 20

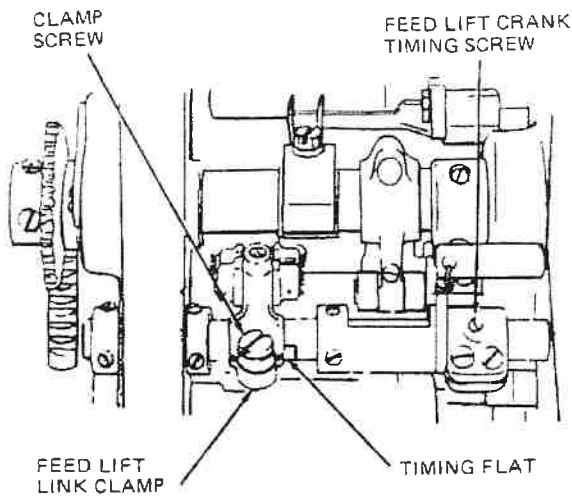

Fig. 21

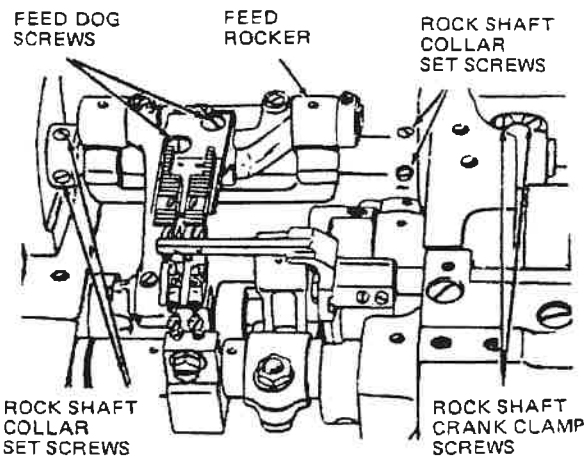

Fig. 22

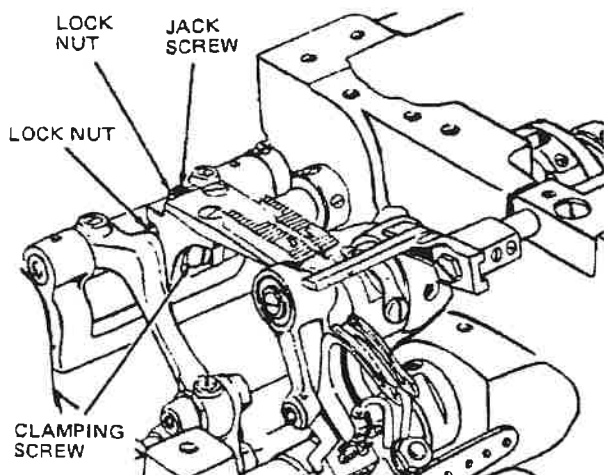

Fig. 23

TO SET FEED BAR AT CORRECT HEIGHT

When the feed bar is set at the correct height, the feed lift link clamp will be aligned with the rock shaft timing flat. To adjust, make certain that the feed lifting crank timing screw, Fig. 21, engages shaft spot correctly. Loosen clamp screw and move the feed lift clamp link to correct position. Then tighten clamp screw.

CENTRALIZING FEED DOG

Sidewise Setting

Needle should enter needle hole of feed dog with the same clearance between the needle and left or right side of hole. To adjust, loosen feed dog screws, Fig. 22. Move feed dog until correct clearance is attained. Hold in position, and tighten feed dog screws.

Additional adjustment, if necessary, may be attained by loosening the four rock shaft collar set screws, the two rock shaft crank clamp screws, Fig. 22, and feed lifting clamp screw, Fig. 21. Move complete assembly to required position and tighten screws.

Lengthwise Setting

The feed dog should clear the ends of the feed slots in the throat plate equally at both ends of feed travel. To adjust, set feed for desired stitch length. Loosen the two rock shaft crank clamp screws, Fig. 22. Move feed rocker forward or backward until correct positioning is attained. Then tighten the two clamp screws.

SETTING FEED DOG AT CORRECT HEIGHT

When the feed dog height is set correctly, approximately the full depth of the teeth will show above the throat plate. To adjust, loosen lock nuts, Fig. 23, and slightly loosen feed dog clamping screw. To raise feed dog turn jack screw clockwise; to lower turn jack screw counter-clockwise and tap feed dog down. When correct setting is attained, tighten the clamping screws and lock nuts.

TIMING FEED LIFT ECCENTRIC

When the feed dog is at its highest position, the top of the teeth should be parallel with, and project full depth of teeth above upper surface of throat plate. To adjust, insert screwdriver in hole in feed strap and loosen the two set screws, Fig. 24. Move feed lift eccentric forward for earlier rise of feed dog, or backwards for later rise. Then tighten the two set screws.

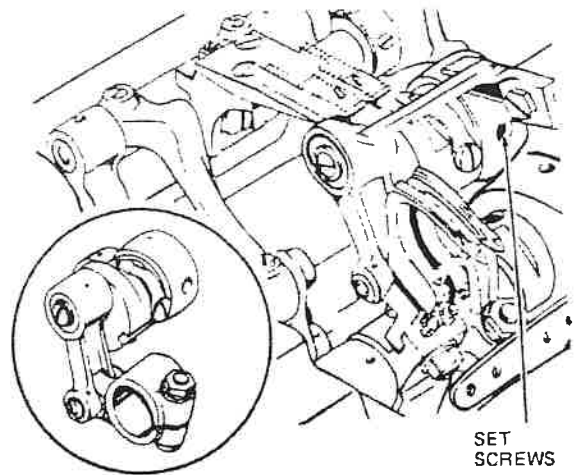

Fig. 24

NEEDLE BAR POSITIONING

Needles should enter needle holes of feed dog toward the front with approximately the same clearance between the front of the needles and the needle holes as at the side. To adjust, press needle bar rock frame, Fig. 25, against drive arm, and at the same time loosen the two driving arm clamp screws. Continue holding the rock frame against the drive arm, move needle bar to correct position and tighten the two clamp screws.

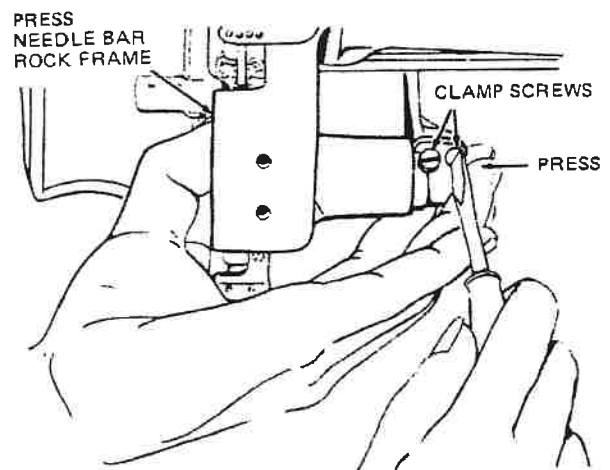

Fig. 25

POSITIONING LOOP DEFLECTORS

When loop deflector, located on underside of feed dog, is positioned correctly, there should be a clearance of approximately 1/32 inch between the right side of the needle and the loop deflector. To adjust, move looper out of sewing position and tilt machine back on its hinges. Loosen loop deflector screws, Fig. 26. Move deflectors toward rear of feed dog as far as the screw slots allow. Tighten slightly to allow for further adjustment. Return looper to sewing position and turn machine pulley until needle bar has descended to bottom of the needle bar stroke. Tap deflector to left or right until correct clearance is attained. Move looper out of sewing position and tighten loop deflector screws.

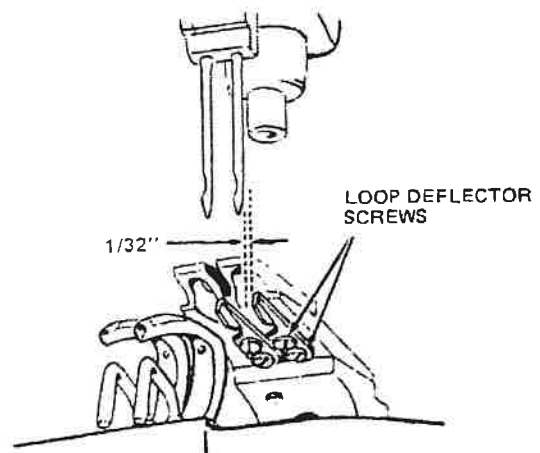

Fig. 26

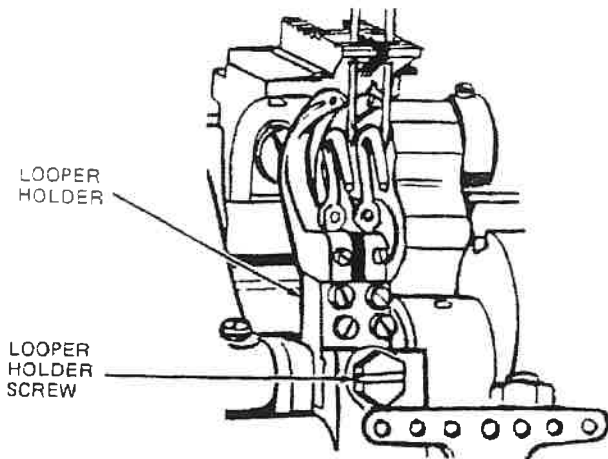

Fig. 27

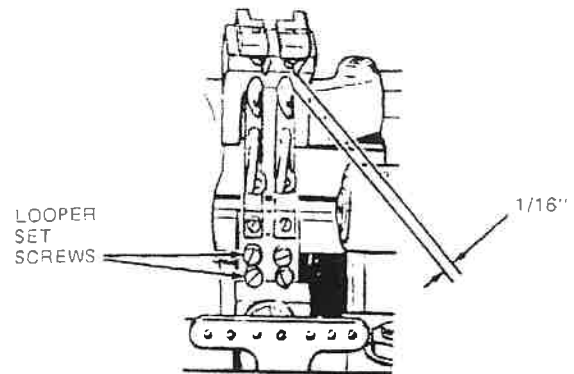

Fig. 28

SETTING THE LOOPER AT CORRECT DISTANCE FROM NEEDLE

Sidewise Setting

When the looper is correctly positioned, the point of the looper just clears the scarf of the needle on the forward stroke of the looper. To adjust, turn machine pulley until the looper point is directly opposite the center of the needle. Loosen looper holder screw, Fig. 27, and tap holder to left or right until correct clearance is attained. Then securely tighten the looper holder screw.

Move looper to extreme forward position. Check clearance between heel of looper and loop deflector, Fig. 28, which should be approximately 1/16 inch. To adjust, loosen the two looper set screws. Turn looper to left or right until correct clearance is attained. Hold in position and securely tighten the two set screws.

CAUTION: On single and multiple needle machines, make certain that the point of each looper just clears the scarf of its respective needle. To adjust, with looper point directly opposite center of needle, loosen the two set screws, Fig. 28, and turn looper slightly to left or right. Then tighten the set screws.

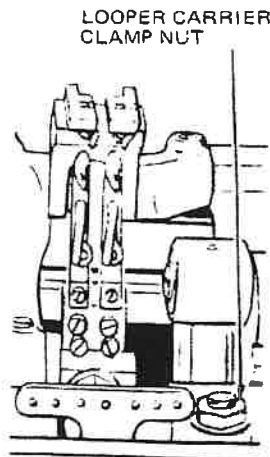

Fig. 29

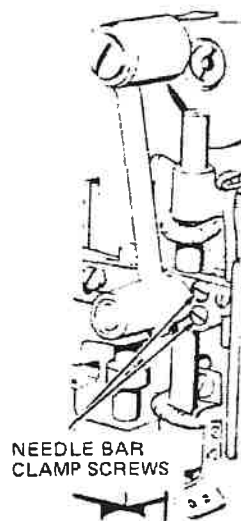

Fig. 30

Lengthwise Setting and Setting Height of Needle Bar

When correctly set, the point of the looper should be directly opposite the center of the needle, and at the center of the clearance above the eye of the needle when the looper timing mark LT on machine pulley is opposite the timing arrow on the arm.

To adjust the looper, loosen looper carrier clamping nut, Fig. 29. Move carrier forward or backward until looper point is directly opposite center of needle. Then tighten clamping nut.

To adjust needle bar, first make certain that needle is inserted up into the needle bar or clamp as far as possible. Loosen the two needle bar clamping screws, Fig. 30, and raise or lower needle bar to correct position. Then securely tighten the two clamping screws.

TIMING LOOPER DRIVING CRANK

When the looper driving crank is properly timed, the point of the looper will pass above the eye of the needle at the same distance on both the forward and backward strokes of the looper.

To adjust when point of looper passes higher on forward stroke, loosen looper driving crank set screw, Fig. 31. Loosen looper crank timing screw (left) approximately 1/8 turn, and tighten looper crank timing screw (right). Continue to adjust until correct adjustment is made. Then securely tighten set screw.

When point of looper passes higher on backward stroke, reverse the adjustment by loosening timing screw (right) and tightening timing screw (left).

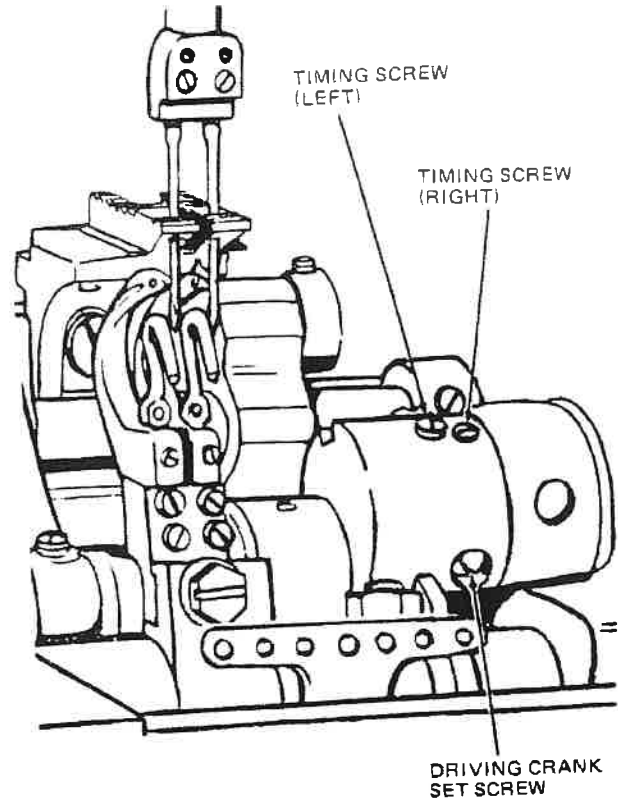

Fig. 31

SETTING THE NEEDLE GUARDS

When needle guards are properly set, they should pass as close as possible to the needles without touching. To adjust, turn machine pulley over toward operator until the points of the loopers are about to pass the needles on their forward strokes. At this point, the looper timing mark LT on the machine pulley should be approximately 1/8 inch above the arrow on machine arm. Loosen needle guard set screws, Fig. 32. Turn needle guards as close to the needles as possible without touching. Tighten set screws. Check by springing the needles to the left and turning the machine pulley to make certain that the looper points do not stroke the needles.

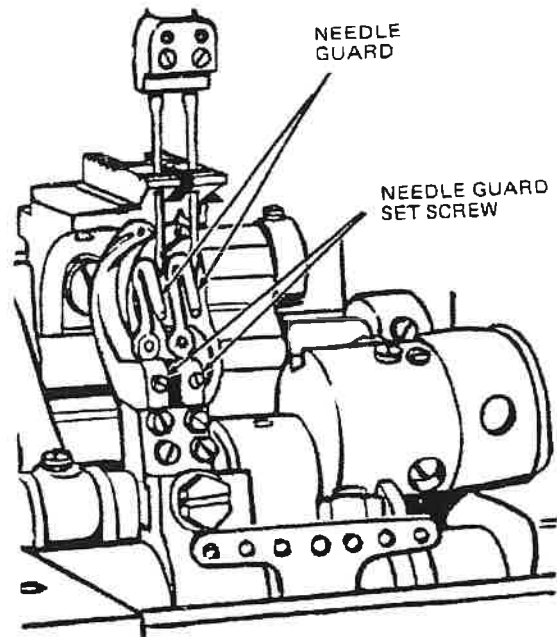

Fig. 32

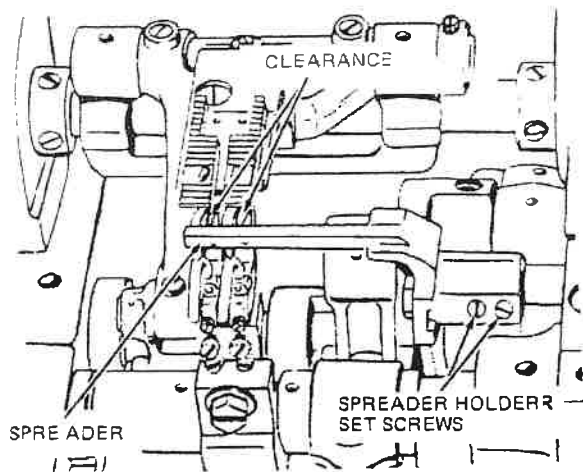

Fig. 33

POSITIONING SPREADER

Sidewise and Height Setting

When looper on its forward stroke is passing spreader

The point of the spreader should be exactly opposite top of thread groove at left side of looper.

The clearance between spreader point and looper should be approximately the double thickness of ordinary paper.

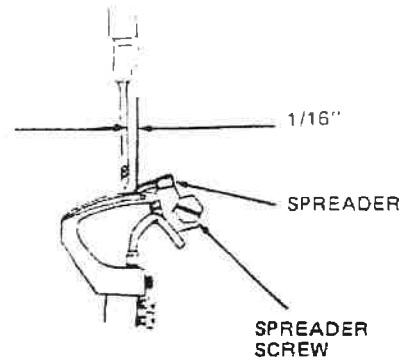

Fig. 34

To adjust, loosen the two spreader holder set screws, Fig. 33. Move spreader and holder to correct position. Hold in position and tighten the set screws.

Lengthwise Setting

When the point of the needle on its downward stroke is even with the point of the spreader, the clearance between the two points should be approximately 1/16 inch. To adjust, loosen spreader screw, Fig. 34, and move spreader forward or backward to correct position. Then tighten spreader screw.

CHANGING MOVEMENT OF SPREADER

The sidewise movement of the spreader may be adjusted for sewing under abnormal conditions. Under normal conditions, maximum spreader movement is generally used. To adjust, tilt machine back on its hinges, loosen the two spreader driving eccentric screws, Fig. 35, and the two spreader driving eccentric flange screws. Move eccentric to left to increase movement, or to right to decrease movement. When correctly positioned, tighten the two spreader driving eccentric screws first, hold flange against strap and tighten flange screws. Then refer to preceding information regarding positioning of spreader.

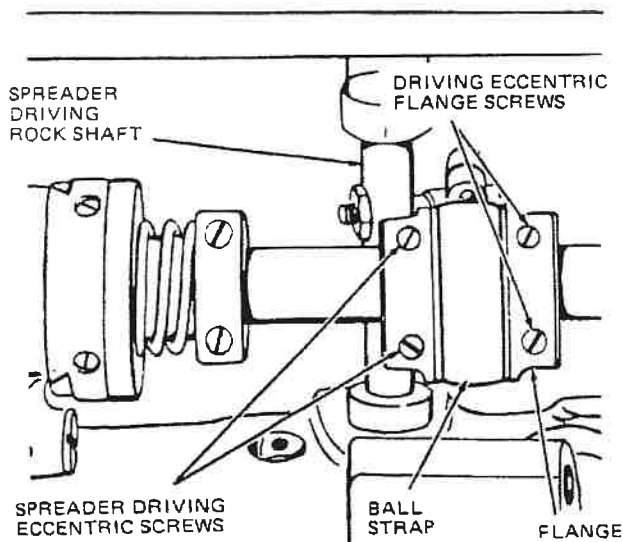

Fig. 35

CAUTION: When increasing sidewise movement, allow sufficient clearance between spreader driving rock shaft, Fig. 35, and left side of eccentric ball strap. They should not touch when eccentric ball stud is in its highest position.

ADJUSTING NEEDLE THREAD TAKE-UP

The needle thread take-up and thread guide may be adjusted to increase or decrease the amount of thread drawn at the top of the needle bar stroke. To increase the amount, loosen thread take-up set screw, Fig. 36, and raise take-up or loosen guide screw and lower the guide. To decrease the amount, reverse the adjustment by lowering the take-up or raising the guide.

For average sewing conditions, the guide should be set with upper end 5/8 inch above the guide screw. The thread take-up should be set with the lower end 1.378 inch below the bottom of its holder.

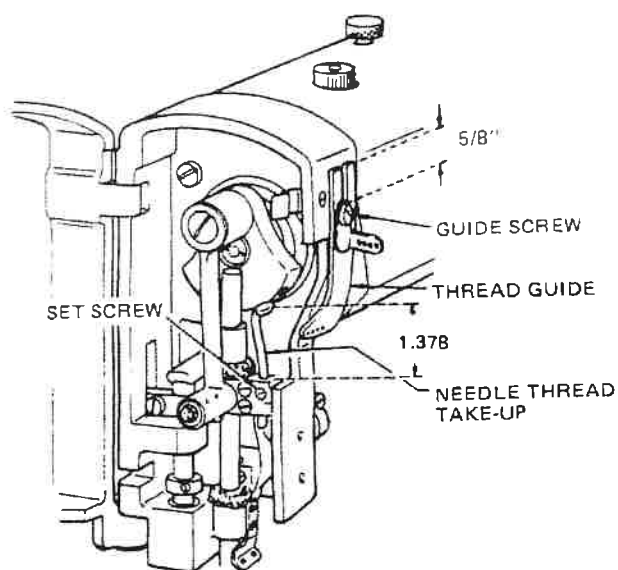

Fig. 36

ADJUSTING NEEDLE THREAD TENSION RELEASER

When correctly adjusted, the tension releaser should release tension on the needle thread when the presser foot is raised and allow full adjusted tension when presser foot is down. To adjust, loosen set screw, Fig. 37, and move tension releaser cap out for earlier release of tension or in for later release. Hold in position and tighten set screw. Should the tension releaser not release tension at the correct time after making the above adjustments, loosen the tension releaser plate screw and move plate sidewise to correct position. Then tighten screw.

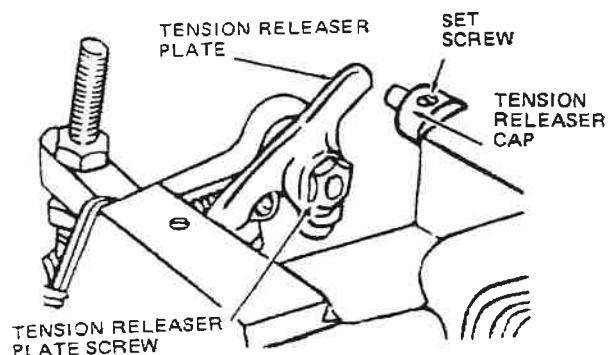

Fig. 37

ADJUSTING LOOPER THREAD TAKE-UP

The looper thread take-up and guide may be adjusted for handling more or less thread, according to thickness of material and length of stitch, and to change the ratio of looper thread in the finished stitch.

To change the amount of thread handled, loosen looper thread guide screw, Fig. 38, and looper thread take-up rod screw. Move thread guide and take-up rod to the left for more thread or to the right for less thread. Tighten the two screws making certain that take-up rod passes through the center of the guide yoke.

To change ratio of looper thread in finished stitch, loosen thread guide screw, Fig. 38, and lower the yoke or right end of thread guide for more thread. For less thread, raise end of guide. Hold in position and tighten guide screw.

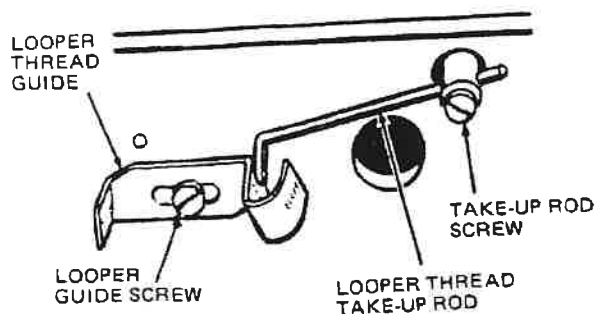

Fig. 38

